

KFG13 to 30 120mm front centres

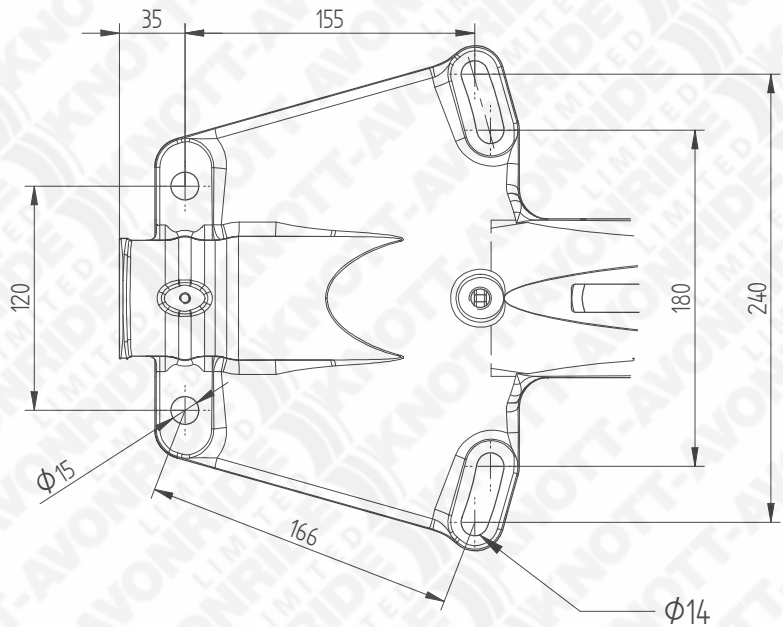

KFG35 120mm front centres

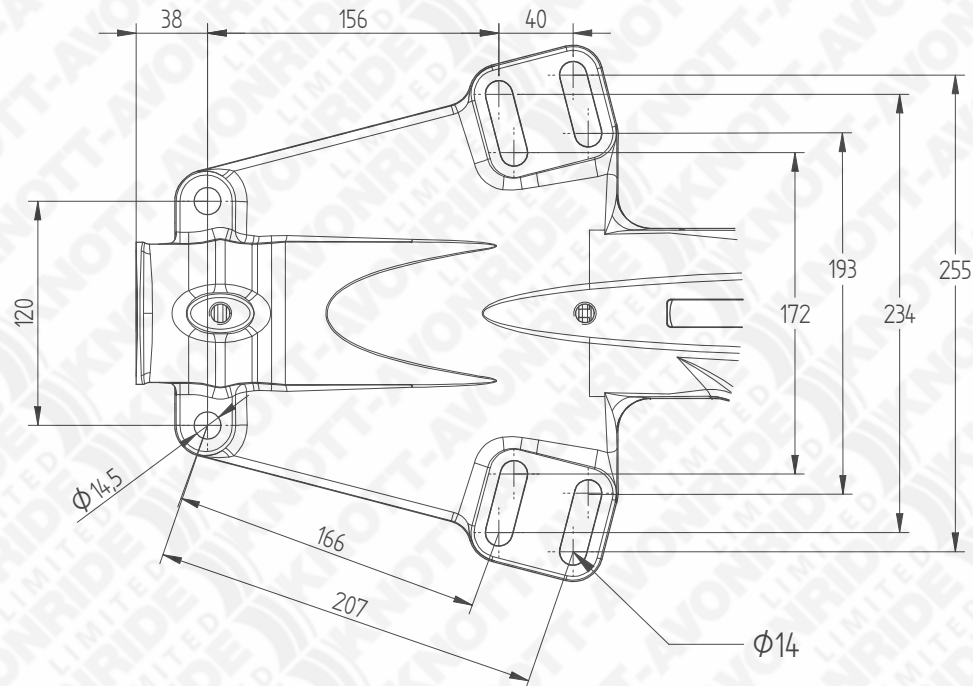

KFG13 to 30 100mm front centres

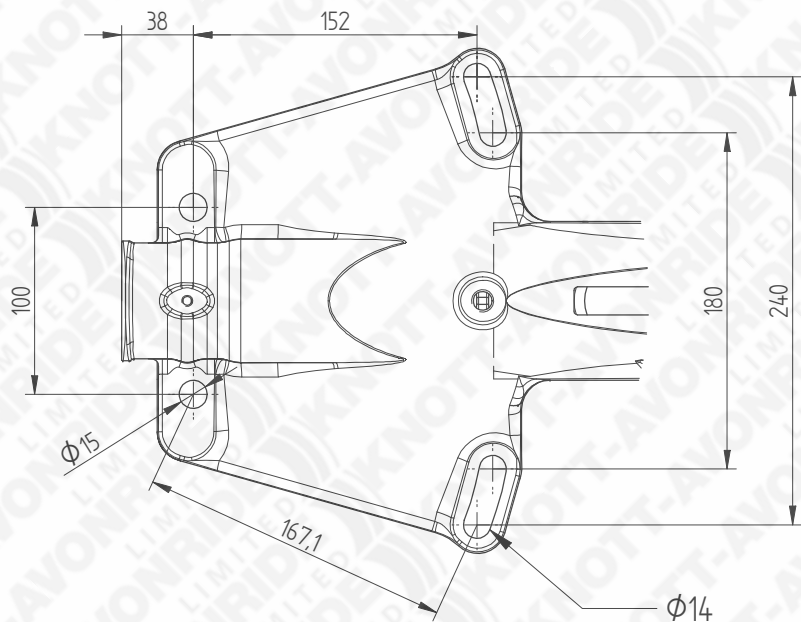

Type	Article No.	Bore Dia. (mm)	Front Hole Centres (mm)
KFG35	504060.120	60	120
KFG30	504050.120	50	120
KFG30	504050.100	50	100
KFG27	504050.120	50	120
KFG27	504050.100	50	100
KFG20	504045.120	45	120
KFG20	504045.100	45	100
KFG13	504045.120	45	120
KFG13	504045.100	45	100

Bolts to DIN931
M12 - Grade 10.9 with Washer Ø13 to DIN7349, 4mm Thick.
M14 - Grade 8.8 with Washer Ø15 to DIN7349, 4mm Thick.

Self Locking Nut
M12 - Grade 10.9 Torque Setting 115 Nm
M12 - Grade 8.8 Torque Setting 80 Nm
M14 - Grade 10.9 Torque Setting 180 Nm

Ab-Schluss Solid-Edge	Intermittent ent. 100mm	Überflachenbezug nach	Spezifikationen für M24-M65-Flanschenbolzen & DIN 934-DIN 934	Alle Maße sind in mm angegeben. Alle Maße sind in mm angegeben.	Bestell-Nr. KDS006
Bestell-Nr. KDS006	08.12.2010	Gezeichnet bfisher	Geprüft KDS006	Zugabe KDS006	Artikel-Nr. KF1006
Produkt NTS	08.12.2010	Gezeichnet bfisher	Geprüft KDS006	Zugabe KDS006	Artikel-Nr. KF1006
KNOTT BRAKE AND TRAILER TECHNOLOGY				KFG Mounting Holes KFG13 to 35	